

U P S

Uninterruptible Power System

ON LINE Network Protection

ON LINE Pure Sine Wave Output UPS

15KVA/ 20KVA

■ USER'S MANUAL ■

TABLE OF CONTENTS

INTRODUCTION	ii
1. IMPORTANT SAFETY INSTRUCTIONS.....	1
2. PRESENTATION.....	2
FRONT PANEL	
REAR PANEL	
OUTPUT	
3. INSTALLATION.....	6
4. OPERATION.....	10
5. ALARMS.....	11
6. SOFTWARE OPTIONS AND COMPUTER INTERFACE PORT.....	12
7. MAINTENANCE AND STORAGE.....	13
8. BATTERY PACK	14
APPENDIX A. TROUBLESHOOTING.....	16
APPENDIX B. SPECIFICATIONS.....	17

Revision 3.0
Revised December 15, 2000.

INTRODUCTION

SAVE THESE INSTRUCTIONS

Please read and save this manual!

Thank you for selecting this uninterruptible power system (UPS). It provides you with a perfect protection for connected equipment. The manual is a guide to install and use the UPS. It includes important safety instructions for operation and correct installation of the UPS. If you should have any problems with the UPS, please refer to this manual before calling customer service.

Please save or recycle the packaging materials!

The UPS's shipping materials are designed with great care to provide protection within delivery. These materials are invaluable if you ever have to return the UPS for service. Damage happened during transit is not covered under the warranty.

Intelligent microprocessor control

The product is an on-line UPS based on dual-microprocessor control. This means that it operates with the newest technology, high performance and powerful function.

The on-line UPS is an intelligent protector and provides pure, reliable AC power to the critical loads - protecting them from utility power blackout, swells, sags, surges and interference.

Beside this, when the utility power is connected, the charger would work automatically even under power switch is OFF. Furthermore, in order to save the battery energy, UPS can automatically turn it off under backup mode if none of the connected loads is operating.

Advanced battery management

The visual and audible indications of the UPS present the battery's status including capacity degree and battery condition. Self-test function let UPS detect a weak battery before it is put into service. The UPS normally perform a self-test at power up and manual self-test condition. Self-test function can be conducted manually with the ON/TEST switch at any time.

Advanced monitoring software

The on-line UPS and UPS-MON series monitoring software (optional kits) make your computer operate intelligent and provide you with the ability of perfect protection of your critical devices. The software is available for most operation systems and is supplied with a communication cable that connects to the UPS.

Note: There is no guarantee that interference to radio/TV will not occur in a particular installation. If this UPS causes interference to radio or television reception, which can be determined by turning the UPS off and on, the user is encouraged to try to correct the interference by one or more of following measures:

1. Connect the equipment to an outlet at a circuit different from the connected radio/TV.
2. Increase the separation between the equipment and the receiver or reorient the receiving antenna.

1. IMPORTANT SAFETY INSTRUCTIONS

IMPORTANT SAFETY INSTRUCTIONS

- **CAUTION (UPS Having Internal Batteries):** Risk of electric shock - Hazardous live parts inside this unit are energized from the battery supply even when the input AC power is disconnected.
- **CAUTION (No User serviceable Parts):** Risk of electric shock, do not remove cover. No user serviceable parts inside. Refer servicing to qualified service personnel.
- **CAUTION (Non-isolated Battery supply):** Risk of electric shock, battery circuit is not isolated from AC input, hazardous voltage may exist between battery terminals and ground. Test before touching.
- **WARNING (Fuses):** To reduce the risk of fire, replace only with the same type and rating of fuse.
- **WARNING:** Intend for installation in a controlled environment.
- **CAUTION:** Do not dispose of batteries in a fire, the battery may explore.
- **CAUTION:** Do not open or mutilate the battery, released electrolyte is harmful to the skin and eyes.
- **CAUTION:** A battery can present a risk of electric shock and high short circuit current. The following precaution should be observed when working on batteries

Remove watches, rings or other metal objects.
Use tools with insulated handles.
- To reduce the risk of electric shock, disconnect the UPS from the mains supply before installing a computer interface signal cable. Reconnect the powers cord only after signaling interconnections have been made.
- Servicing of batteries should be performed or supervised by personnel knowledge of batteries and the required precautions. Keep unauthorized personnel away from batteries.
- The right way to de-energize the UPS properly in an emergency is to move the I/O switch to the OFF position and disconnect the power cord from the mains supply.

2. PRESENTATION

Front LCD Panel

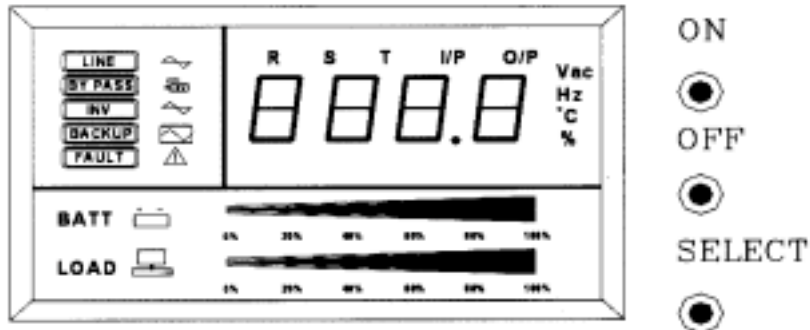

2.1 “LINE” indicator

The indicator illuminates when the line input voltage is normal.

2.2 “BY PASS” indicator

The indicator illuminates when the loads are supplied from the utility power, through the by-pass direction.

2.3 “INV” indicator

The indicator illuminates when the output power of UPS is supplied from the inverter circuit.

2.4 “BACKUP” indicator

The indicator illuminates when the power is supplied from the batteries.

2.5 “FAULT” indicator

It shows something wrong concerning about the UPS.

2.6 “ON” button

With the UPS plugged in, press the “ON” button to turn on the UPS and power the loads. “ON” also activates the UPS’s self-test and utility line voltage displays.

2.7 “OFF” button

Press the OFF button to turn off the UPS and the loads.

2.8 “SELECT” button

The relevant value appears at the upper screen. There are four display modes can be selected.

- Output voltage display
- Input voltage display
- Input frequency
- Temperature inside the UPS

2.9 “BATT” bar graph (RECTANGLE INDICATOR)

The rectangle indicator shows the percentage of battery capacity.

2.10 “LOAD” bar graph (RECTANGLE INDICATOR)

The indicator shows the power being drawn by the load.

2.11 “FAULT” codes

The relevant value appears at the upper screen. There are seven kinds of fault modes can be displayed.

- E01: Warning of fail output
- E02: Wrong of wrong temperature
- E03: Warning of output short circuit
- E04: Warning of overload (exceeding 150%)
- E05: Warning of mistaken +/- DC Bus
- E06: Warning of wrong electrical charging voltage
- E07: Warning of batteries mistake

<u>Load Indicator</u>	<u>% of Load Value</u>	<u>Battery Indicator</u>	<u>% of Bat Level</u>
Light no.5	over 96%	Light no.5	over 91 %
Light no.4	76-95 %	Light no.4	76-90 %
Light no.3	51-75 %	Light no.3	51-75 %
Light no.2	26-50 %	Light no.2	26-50%
Light no.1	10-25 %	Light no.1	0-25%

Rear Panel

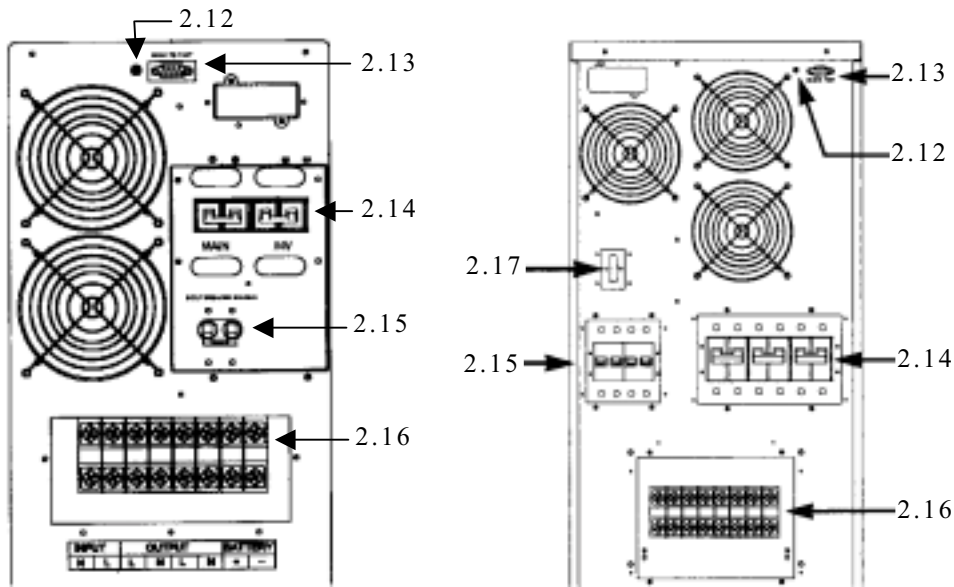

2.12 “OUTPUT VOLTAGE” button

Attention: Only the engineers authorized by the producer can use this button. Don't try to adjust the voltage by yourself.

2.13 “COMPUTER INTERFACE” connector

Provide both RS-232 and relay signal to support NOVELL, UNIX, DOS, WINDOWS and other operating systems.

2.14 “SWITCH”

“Inverter Switch”
 “Maintain Switch”
 “Battery Switch”

2.15 “INPUT SWITCH and CIRCUIT BREAKER”

It trips when the connected loads exceed the protected receptacle's capacity, The center plungers of the circuit breakers extend when tripped.

2.16 “TERMINAL”

Input: Connect the input voltage

Output: Connect the output voltage.

The connecting way can be changed if there is an output isolated transformer.

Batteries: Can be connected with external batteries.

2.17 “EXTERNAL BATTERY PACK” connector(8K/10K/12K)

Batteries: Can be connected with external battery pack.

2.18 Unpacking and Inspection

If you should find any damages on the outer carton, please contact the delivering units such as carriers or forwarders. Keep a good storage of the outer carton with all the wrapping materials inside, it will help you pack the UPS for the future transportation, if there is any.

3. INSTALLATION

Inspect the UPS upon receipt. The packaging is recyclable; keep it for reuse or be disposed of properly.

3.1 Placement

Install the UPS in a protected area with adequate flowing air and free of excessive dust. Do not operate the UPS where the temperature and humidity is outside the specified limits.

3.2 Connect Computer Interface (optional)

UPS-MON series software (or other power management software) and an interface kits can be used with this UPS. Use only kits supplied or approved by the manufacturer. If used, connect the interface cable to the 9-pin computer interface port on the back panel of the UPS.

Note: Computer interface connection is optional. The UPS works properly without a computer interface connection.

CAUTION: Use only factory supplied or authorized UPS monitoring cable!

3.3 Connect external battery pack (optional)

Before connecting, make sure the external battery pack and the connector cable are compatible.

Note: External battery connection is not necessary. The UPS works properly without external battery pack connection. (For standard model only)

CAUTION: Use only factory supplied or external battery connection cable!

3.4 Charge the battery

The UPS charges its battery whenever it is connected to utility power. For best results, charge the battery for 8 hours in the initial use.

3.5 Connect to Utility

See figure a, b and c. Please check the following items to connect the AC input power to terminal block and power up the UPS.

- 3.5.1. The capacity of the breaker on the wiring board must be over 125A.
- 3.5.2. Please use the wiring cords whose diameter is over 6AWG(soft cord) or 38mm² (hard cord).
- 3.5.3. If the switchboard of the environment is 3 Φ /3 wires (Δ type), another isolated transformer at the input side should be added. The utility input need to transfer as 3 Φ /4 wires (Y type) by the isolated transformer, first. After that, the utility power with 3 Φ /4 wires (Y type) can be connected with the UPS.
- 3.5.4. When you install the wires at the switchboard and UPS (3 Φ /4 wires, Y type), please check the following condition is matched.
 - 3.5.4.a. The NFB capacity of I/P at the R phase & N phase input side is more than 125A.
 - 3.5.4.b. The NFB capacity of I/P at the S phase input side is more than 100A.
 - 3.5.4.c. The NFB capacity of I/P at the T phase input side is more than 100A.

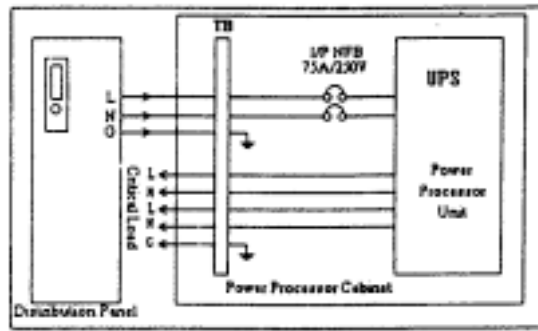

Figure. a

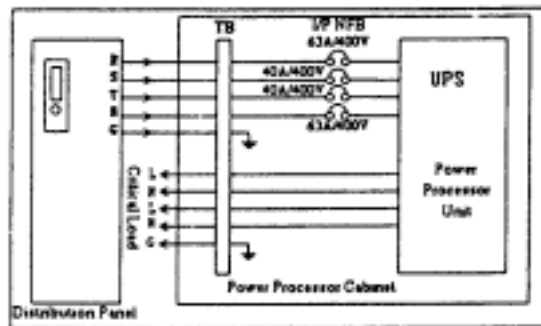

Figure. b

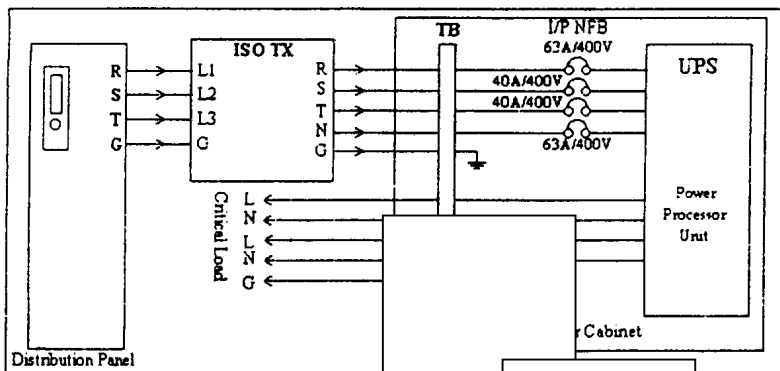

Figure. c

3.6 Connect the loads

Connect the loads with the terminal block at the rear of the UPS. To use the UPS as a master on/off switch, make sure all of the loads are switched on.

CAUTION: Never connect a laser printer or plotter to the UPS with other computer equipment. A laser printer or plotter periodically draws significantly more power than when its idle status, and may overload the UPS.

3.7 Wiring

If you choose to adapt with an isolated transformer, you should see the following figure No.1-No.3 for reference.

Attention: The output cord can be Single-phase-2-wire and Single-phase-3-wire.

1. Install it to be Single-phase-2-wire for the users who use 110V facilities only. It won't burn down the internal transformer of UPS when the UPS is operating with full load status.
2. If the output is setup to be 110V, please use the wiring cords whose diameter is over 100 mm² (hard cord) .

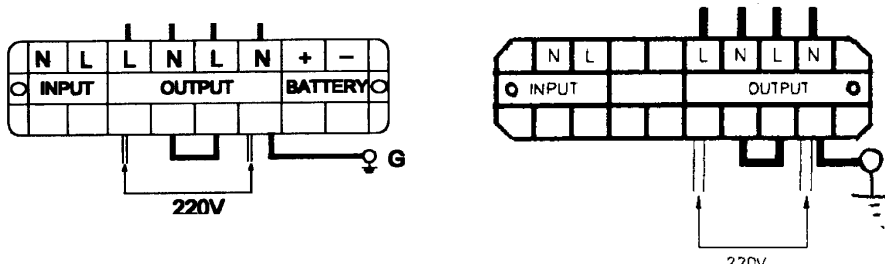

1 Φ /2 wires, 220V
Figure. No 1

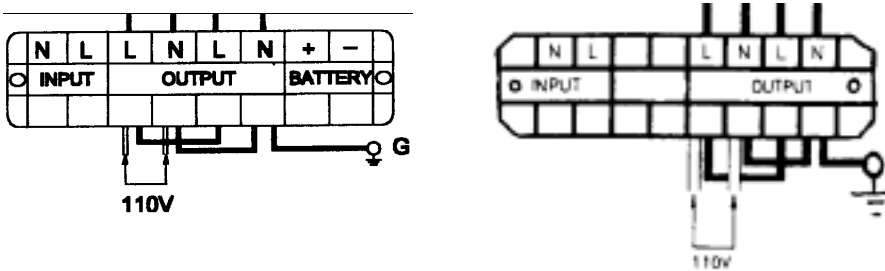

1 Φ /2 wires, 110V
Figure. No 2

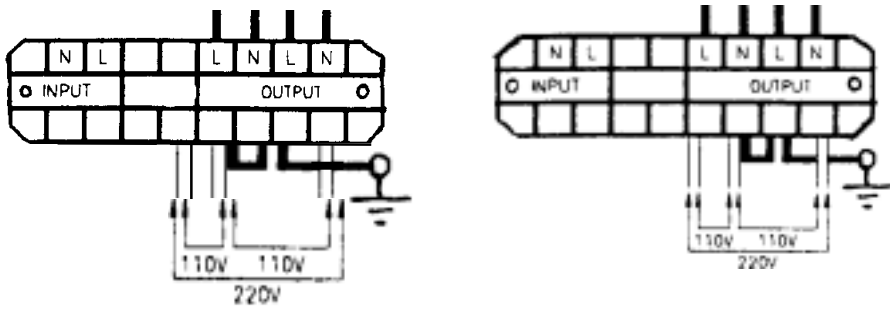

1Φ/3 wires, 110V
Figure. No 3

Attention: For 15K/20K models, 6AWG(soft cord) or 38 mm² (hard cord) for 1Φ/2W 220V and 1Φ/3W.

4. OPERATION

4.1 Switch on

While utility input is connected to the UPS, press the "ON" button and keep pressing over than 0.5 second. After that, connect the electrical cords of the equipment that is going to be used such as computer or monitor with the terminal on the rear panel of UPS.

Don't overload the machine with all the equipment used. The buzzer will beep continuously to indicate overload status. UPS will shut down automatically to protect the machine.

Attention: If the power of UPS isn't supplied by utility but by the internal batteries to engage the UPS, press the "ON" button and keep pressing for over 3 seconds.

CAUTION: Never connect a laser printer or plotter to the UPS with other computer equipment. A laser printer or plotter periodically draws significantly more power than when its idle status, and may overload the UPS.

4.2 Switch off

By pressing and holding OFF button until the "LINE NORMAL" or "BACK UP" LED off.

4.3 Silence

When UPS is under "BACKUP" mode, press "ON" button more than 1 second to silence the audible alarm. (The function is disable when UPS is under condition of "LOW BATTERY" or "OVERLOAD")

Note: At back-up mode, UPS can be automatically turned off if none of the connected loads is operating.

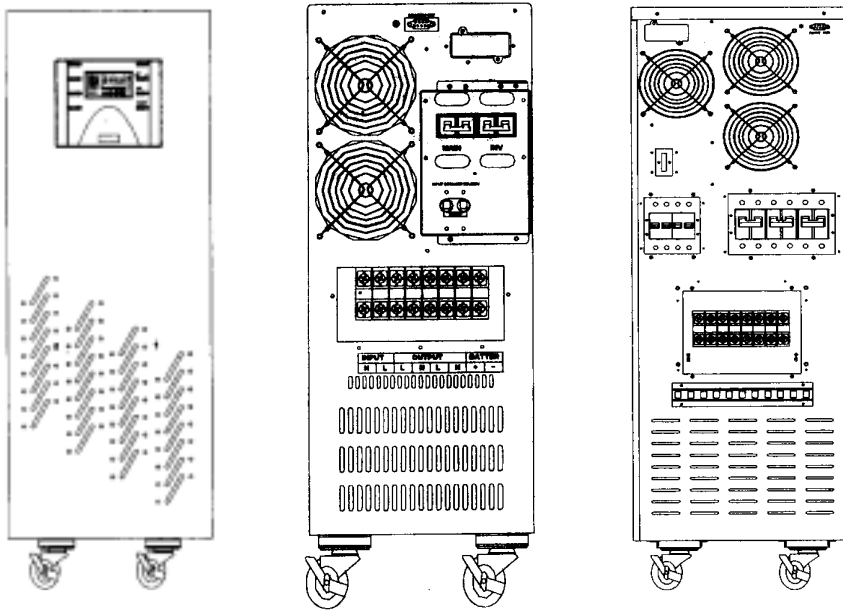

Figure. Front and back Panel

5. ALARM

5.1 "BACKUP"(slow alarm)

When the UPS is working under "BACKUP" mode, the UPS would emit audible alarm. The alarm stops when the UPS is return to "LINE" mode operation. Anyone can stop the alarm by press the "ON" button during backup mode.

Attention: The alarm of "BACKUP" is going to beep every four seconds. (Slow-speed beep).

Attention: The UPS provides mute function for the warning. When the beeping sound occurs, press "ON" to stop it; and press "ON" again to regain the sound.

5.2 "LOW BATTERY" (rapid alarm)

In the "BACKUP" mode, when the energy of battery becomes to lower level. (about 20%~30%) The UPS beeps rapidly until the UPS shuts down from battery exhaustion or returns to "LINE" mode operation.

Attention: The alarm of the batteries caused by low voltage beeps every second. (Fast-speed beep).

Attention: The rapid alarm under "LOW BATTERY" condition can't be erased.

5.3 "FAULT" (continuous alarm)

Here is listing some "FAULT" conditions as following for reference.

5.3.1 "FAULT code 04"

When the UPS is working under overload condition (the connected loads exceed the maximum rated capacity), the UPS will emit continuous alarm to warn an overload condition. In order to protect the unit and the loads, the UPS will be automatic shutdown. Disconnect nonessential devices from UPS to eliminate the overload alarm.

5.3.2 "FAULT code E07"

The UPS emits continuous beeps and the "FAULT" illuminates if the battery fails within the self-test. See section 8 to replace battery and call your dealer for services.

6. SOFTWARE AND INTERFACE PORT

6.1 Power Monitoring Software

The UPS-MON series software (or other power monitoring software) is applied standard RS-232 interface to perform monitoring functions, and then provides an orderly shutdown of a computer in the event of power failure. Moreover, UPS-MON displays all the diagnostic symptoms on monitor, such as Voltage, Frequency, Battery level and so on. The software is available for DOS, Windows 3.1x, Windows 95, Windows NT V3.5 or later, Novell Netware and others. Call your dealer for more information on computer OS compatible solutions.

6.2 Interface Kits

A series of interface kits is available for operation systems that provide UPS monitoring. Each interface kit includes the special interface cable required to convert status signals from the UPS into signals which individual operating system recognize. The interface cable at UPS side must be connected to REMOTE PORT, at computer side can be either COM 1 or COM 2. The other installation instructions and powerful features please refer to READ.ME file.

CAUTION: Use only factory supplied or authorized UPS monitoring cable!

6.3 The characteristics of computer interface port

The computer interface port has the following characteristics:

The communication port on the back of the UPS may be connected to host computer. This port allows the computer to monitor the status of the UPS and control the operation of the UPS in some cases. Its major functions normally include some or all of the following:

- To broadcast a warning when power fails.
- To close any open file before the battery is exhausted.
- To turn-off the UPS.

Some computers are equipped with a special connector to link with the communication port. In addition, special plug-in cord may be needed. Some computers may need special UPS monitoring software. Contact your dealer for the details on the various interface Kits.

6.4 The pin of computer interface port

The pin of computer interface port has the following characteristics:

- 6.4.1. Pin 5 and 2 are open collector outputs that must be pulled up to a common referenced supply no greater than AC +40V. The transistors are capable of a maximum nonconductive load of DC 25 mA, Use only pin 7 as the common.
- 6.4.2. Pin 5 generates a High to Low signal when the battery inside the UPS has less than 5 minutes back up time left.
- 6.4.3. Pin 2 generates a High to Low signal when the line is fail.
- 6.4.4. The UPS will shut down when a high RS-232 level is sustained on pin 6 for 0.36 seconds.
- 6.4.5. Pin 9 is also the RS-232 data output.
- 6.4.6. Pin 6 is RS-232 data input (RxD)

NOTE:

- 1. Switch rating +40V, 0.15A non-inductive.
- 2. Pin 7 should be connected to ground only.

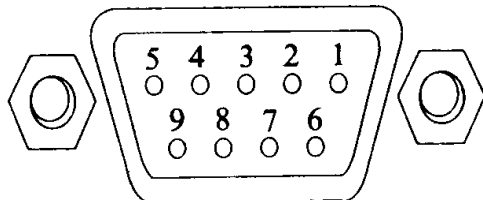

7. MAINTENANCE AND STORAGE

7.1 Maintenance

- 7.1.1. Keep the unit clean and vacuum the ventilation intake periodically.
- 7.1.2. Wipe with soft loose and damp cloth.
- 7.1.3. Check for loose and bad connections monthly.
- 7.1.4. Never leave the unit on an uneven surface.
- 7.1.5. Position the unit to allow at least 10 cm clearance between the rear panel and the wall. Keep the ventilation intake open.
- 7.1.6. Avoid direct sunlight, rain and high humidity.
- 7.1.7. Stay away from fire and extremely hot location.
- 7.1.8. Do not stack materials on top of the unit.
- 7.1.9. The unit should not be exposed to corrosive air.
- 7.1.10. The normal operating temperature is 0-40 °C.

7.2 Storage conditions

Store the UPS covered and upright in a cool and dry location, with its battery fully charged. Before storing, charge the UPS for at least 4 hours. Remove any accessories in the accessory slot and disconnect any cables connected to the computer interface port to avoid unnecessary draining the battery.

7.3 To extend the storage

During the environment where the ambient temperature is -15 to +30 °C (+5 to +86 °F), charge the UPS's battery every 6 months.

During the environment where the ambient temperature is +30 to +45 °C (+86 to +113 °F), charge the UPS's battery every 3 months.

8. BATTERY PACK

8.1 Battery's life of UPS

The battery's life of UPS is about 3-6 years under normal usage.

8.2 Battery Replacement

See figure. UPS and external battery pack.

Once the UPS's battery is no longer useful and must be replaced. Please follow the instructions for easy battery replacement.

8.2.1. Unplug unit from AC power source and disconnect all connected equipment.

8.2.2. Disconnect AC power cord from UPS.

8.2.3. Make serial connection of the battery packs (20 pcs). Make sure they are at proper voltage.

8.2.4. First, connect the electric wire with the ends of the battery packs.

Attention: Do not connect it with the end of UPS, or it will cause an electrical shock. The red wire with a tag should be connected with the positive end(+) of the battery packs; connect the black wire with the negative end(-) of the battery packs.

8.2.5. Connect with the utility while the UPS is at its no-load position.

8.2.6. Connect the battery terminals on the rear panel connector of UPS with the electrical wires of battery series. (See the following picture.)

Attention: The positive/negative ends of the electric wire of batteries should be at the same position as the positive/negative ends of the connector on UPS rear panel. That is, the positive ends of the electrical wire of batteries should be connected with the positive ends of the connector on UPS rear panel; the negative ones with the negative ones of the connector. If not, there will be an explosion danger.

8.2.7. You can now easily remove the battery from the UPS

CAUTION: Do not dispose of battery in fire.

CAUTION: Do not attempt to open the battery.

CAUTION: The following precautions should be taken when replacing the battery

- a. Remove watches, rings, etc...
- b. Use tools with insulated handles

8.2.8. Place your new battery in the same position/direction and reconnect the red wires to positive (+) polarity and black wire to negative (-) polarity.

8.2.9. Please follow steps 5,4 and 3 (in that order) to reconnect the entire unit.

8.2.10. Please follow manual instructions to reconnect your equipment.

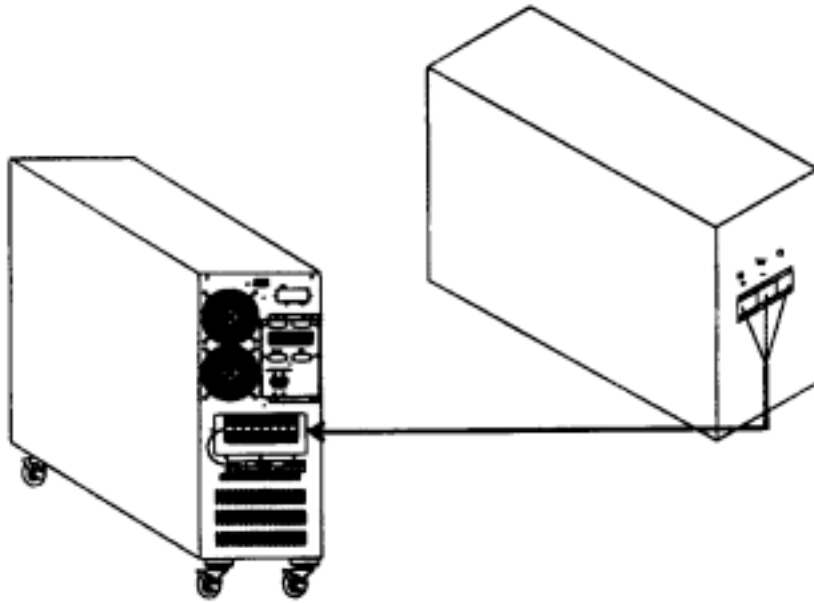

Figure. UPS and external battery pack (8K/10K/12K)

APPENDIX A TROUBLESHOOTING

Problems	Possible Reasons	Solutions
1. UPS can't operate after pressing On/Off switches	Input power source mistake	Check out the power source
	Non-fuse switch on the rear panel hasn't been opened	Press the non-fuse switch to its "on" position
2. No lights on, no warning sounds	Time of pressing the ON button is too short	Keep pressing the ON button over 1 second
	Output short circuit or overload on UPS	Turn off UPS, take off all load to make sure there are no problems on it or any internal short circuit. Keep pressing the ON button over 1 second
Indicates no utility, and it warns every several seconds	No power source input	Check out the input power source
	Non-fuse switch on the rear panel hasn't been opened	Press the Non-fuse switch to its "on" position
Fault light is on, the buzzer keeps beeping	UPS is broken	Contact the dealer or service center for help
Buzzer keeps beeping	Overload	Take off some load
Utility Indicating light is shining	There is an open circuit on UPS input protector	Move the Input Non-fuse switch back to its normal position, re-engage UPS
	The voltage of utility is exceeding UPS input range	Save the digital data and shutdown the applying program to make sure utility is within UPS range
Available time of the batteries is too short	1. Batteries haven't been charged 2. UPS overload 3. Batteries are aged and can't be charged fully	Keep UPS "ON" for over 3 hours to recharge the batteries. Check out the loading and take off any non-crucial load equipment
	The charger is out of order	Contact the dealer or service center for help
The batteries light is flashing when the power of UPS is supplied by utility.	The voltage of batteries is too low or the batteries haven't been connected	Check out the batteries part of UPS, make sure they are well connected. If there is any damage on battery packs, replace new ones ASAP

APPENDIX B SPECIFICATIONS

Limited Capacity		15KVA/10.5KW	20KVA/14KW
AC Input	Voltage	294V~478V 3 Φ /4 wires	
	Current(3 Φ)	26A max	34A max
	Frequency	50Hz or 60Hz+/-3Hz	
	Power Factor	>=0.95 3 Φ /4 wires	
AC Output	Voltage	208/220/230/240/Vac +/-2% (can be changed to 110Vac if connected with an isolated transformer)	
	Current	72A max	96A max.
	Frequency	60Hz or 50Hz +/- 0.5%	
	Power Factor	0.7 (Lagging)	
	Transient Reaction	100% Load Variation +/- 4%, back to +/- 1% within 2ms	
	Harmonic distortion	<5 % of T.H.D. at linear load	
	Overload detection	>105% for 10 seconds, >130 \pm 10% for 300ms	
Batteries	Standard setup	240V Sealed, Maintenance-free lead acid	
Interface	RS232	Adaptable with UPSMON on-line Monitoring software. Instant Indicated with graphs.	
Environment	Temperature	0 degrees - 40 degrees Celsius	
	Humidity	0 – 95%	
	Sea Level Height	Less than 1500 M (above sea level)	
	Storage Temperature	-25 to 55 degrees Celsius	

there are any changes of the specification in the future, it's all subject to the producer to notify.

The user's manual content is correct at the time of printing product specifications are subject to change without prior notice

Communicating Interface Port

We provide a standard RS232 line (that is compatible with DB9 line) socket on the rear panel of UPS. That port possesses several signals as explained below:

Pin#	Function Explanation	I/O
2	Power Fail-normally open status, will become closed during active	OUTPUT
4	Reference GND for pin2,5	OUTPUT
5	Battery Low- normally open status, will become closed during active	OUTPUT
6	Remote shutdown UPS-keep this pin at high voltage(+5V~+12V) 500ms to shutdown UPS. Activates at battery mode	INPUT
7	Reference GND for pin6	INPUT